

eLITE

battery monitor

INSTALLATION GUIDE

Please read this document very carefully to avoid battery monitor malfunction and/or fire hazards!

Mounting sequence

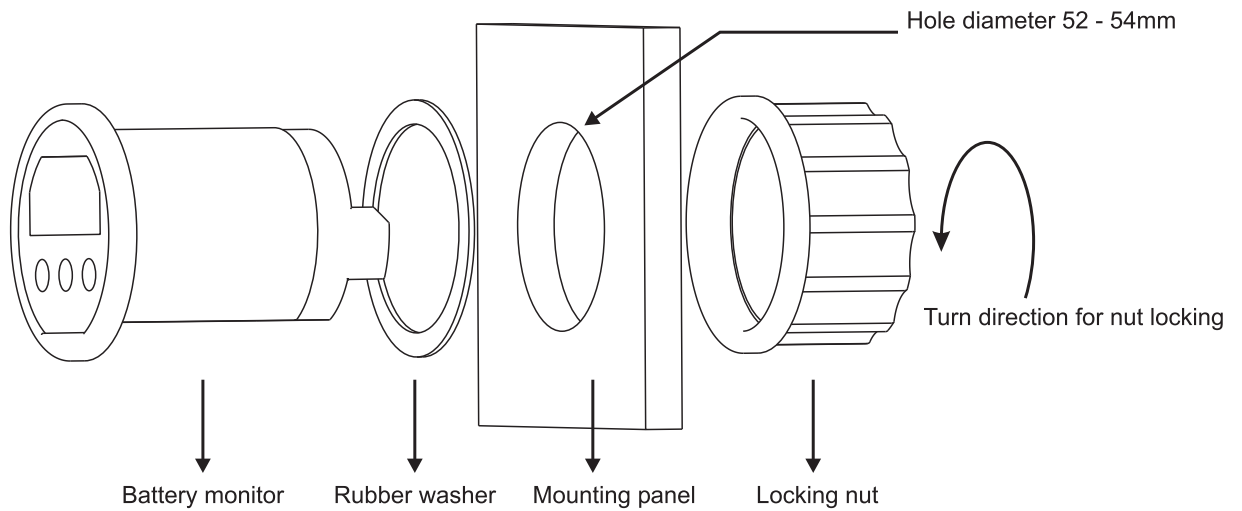

Battery positive 'MAIN' (to load e.g. charger or inverter)

Battery negative (system ground)

Battery positive 'AUX' (to load e.g. charger or starter motor)

* Make sure the batteries you install are always in good health, preferably fully charged

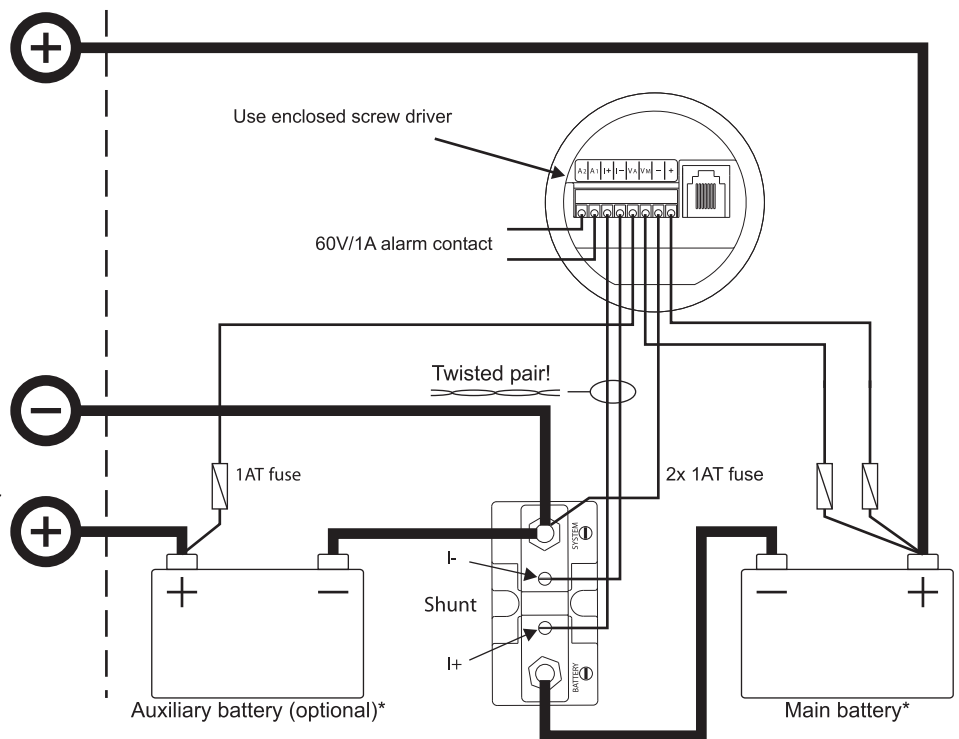

The shunt must always be installed into the negative line! Installing the shunt into the positive line may damage the battery monitor!



All fuses must be located as close as possible to the battery terminals. Install the fuses only when all other connections are made and double checked!



All thick lines in the above connection diagram, represent the main current lines. These lines must be wired with a wire type which can handle the full battery current!



All thin lines (from and to battery monitor) in the above connection diagram, must have a minimum thickness of AWG24/0.2mm². Maximum distance between battery monitor and shunt is 30 meters.



To avoid large errors in current measurement, always twist the 'I+' and 'I-' shunt lines. Connect all wires to the shunt exactly as given in the connection diagram.

Battery monitor connection terminals :

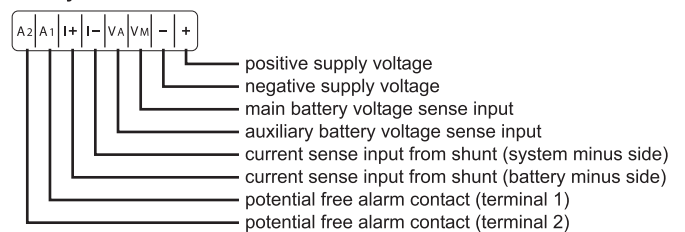

eLITE

battery monitor

QUICK START GUIDE

This column describes the absolute minimum number of required steps in order to setup your Battery Monitor.

When all fuses are installed, the battery monitor will startup with a blinking display in MAIN battery voltage readout selection. When pushing one of the three buttons, the LCD stops blinking and you can navigate through all readout selections using the V, A/Ah and % keys. The battery monitor now operates in the Normal Operating Mode. The following readout selections can be made :

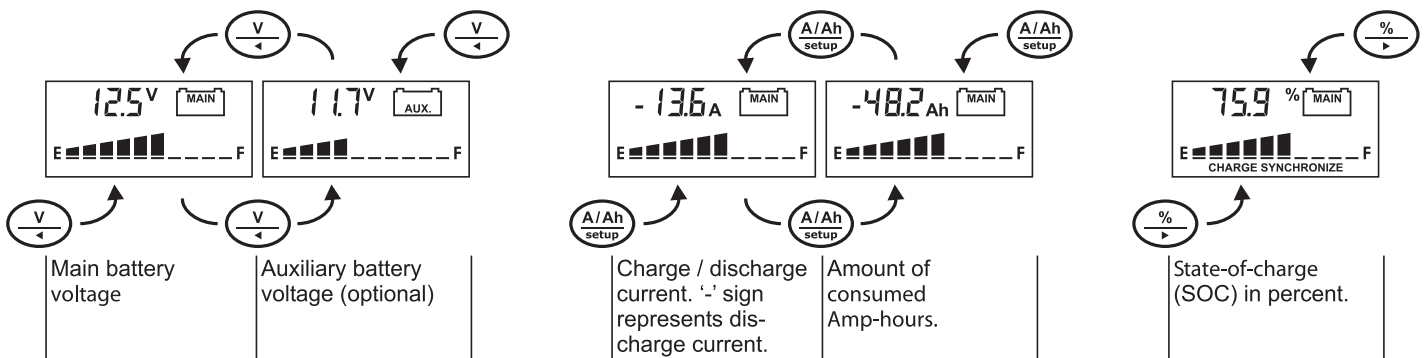

The display also indicates **SYNCHRONIZE**. As will be further explained in the owner's manual, this message means that the battery needs to be fully charged first, in order to synchronize the battery monitor with the battery. Otherwise, the State-of-charge readout will be invalid. The more often you are fully charging your batteries, the more precise the battery monitor will indicate all parameters. This will also result in a longer lifetime of your batteries.

But before the batteries can be fully charged, you first need to adjust or check Functions F01 (BATTERY CAPACITY), F02 (Charger's float voltage) and F05 (low battery alarm in Volts). Setting these Functions to the right values, will in most cases result in a correctly operating battery monitoring system. Please follow the instructions in the Owner's manual on how to adjust or check all Functions.

Troubleshooting guideline

Problem	Remedy or suggestion
The monitor doesn't operate (no display)	<ul style="list-style-type: none"> - Check monitor- and battery side connections. - Make sure the inline fuses are installed and not blown. - Check battery voltage. Battery might be flat. Vbatt must be >8VDC. - Try to restart the monitor by removing / placing the fuses again.
Current readout gives wrong polarity (positive current instead of negative when discharging)	<ul style="list-style-type: none"> - Current sense leads from the shunt are reversed. Check the installation guide.
The monitor resets all the time	<ul style="list-style-type: none"> - Check the wiring for corrosion and / or loose contacts. - Battery might be flat or defective.
"CHARGE" or "SYNCHRONIZE" keeps on flashing	<ul style="list-style-type: none"> - Charge battery full (synchronize your battery with the monitor) - Check the Auto-sync parameters in Functions F02 and F03 for possible wrong settings.
State-of-charge (%) reading not accurate	<ul style="list-style-type: none"> - Check if all current is flowing through the shunt (the negative terminal of the battery may only contain the wire going to the battery-side of the shunt!). - Current sense leads from the shunt are reversed. - Check Battery capacity setting (F01) - Check if battery monitor is synchronized.



Unit 11, 1029 Manly Road, Tingalpa, 4173
 PO Box 9159 Wynnum Plaza, Qld, 4178
 Ph: 1300 851 535 Fax: 07 3390 6911
 Email: sales@enerdrive.com.au
 Web: www.enerdrive.com.au